



## Rowan County NC Wayfinding . Boulevard Scale Signage

China Grove • Rockwell • Cleveland

Landis • Spencer • East Spencer • Granite Quarry • Faith

Final Revision / March 12, 2024



**BIZZELLDISIGN**

WAYFINDING  
BRAND / IDENTITY  
URBAN IDEAS

**ROWAN  
COUNTY**

NORTH CAROLINA

*Be an original.*

Wayfinding /  
Typical Wayfinding Fabrication Details

MUTCD Lettering is Highway Gothic  
 ABCDEFGHIJKLMNOPQRSTUVWXYZ  
 abcdefghijklmnopqrstuvwxyz 1234567890

MUTCD Approved Breakaway  
Base Construction



The **principal legend** on guide signs shall be in letters and numerals at least 6 inches in height for all upper-case letters, or a combination of 6 inches in height for upper-case letters and 4.5 inches in height for lower-case letters.

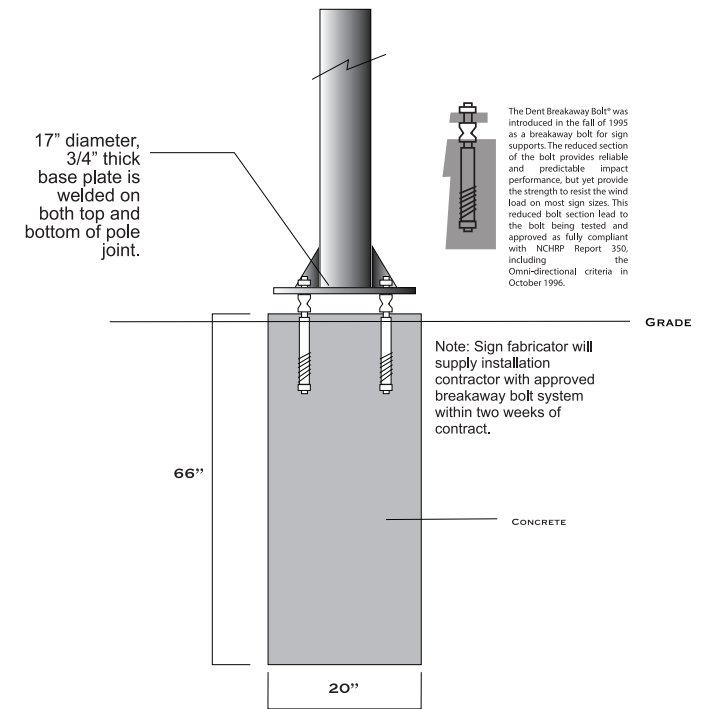

Masonry/Footings

Any concrete bases for signage are to be poured in place and footings are to extend beneath the frost line, or deeper to meet local code. All footings or bases should be poured within a form and 2" above grade unless otherwise specified in the design intent drawings. It is recommended that the concrete be floated by hand before finishing in order to embed larger aggregates. Concrete surface should have a smooth or brushed finish grade appearance. All concrete bases and footings should be edged to break any bond with the form and create a neat appearance. All forms should be removed once the concrete has properly cured. Concrete and reinforcement specifications shall be shown on shop drawing submittals. The fabricator is responsible for the necessary templates, mounting plates and hardware for concrete and masonry bases. A minimum 1' rock bed with landscape edging or concrete pad must be added around each concrete base as protection from landscaping maintenance.

MUTCD  
APPROVED  
BREAKAWAY  
MOUNTING

28- large  
Wayfinding Sign Req.



**Wayfinding / Fabrication / Messaging Details**

The **principal legend** on guide signs shall be in letters and numerals at least 6 inches in height for all upper-case letters, or a combination of 6 inches in height for upper-case letters and 4.5 inches in height for lower-case letters.



Pantone 3308



MPC - 33764



3M™ Diamond Grade™  
DG<sup>3</sup> Reflective Sheeting  
Series 4000

2 - 150  
Driving East positioned on Hwy 150  
500 ft. West of Caldwell Rd.

2 - 150  
Note: Sign  
production &  
location number  
is to be printed on  
sign panel in 1/4"  
tall letters.

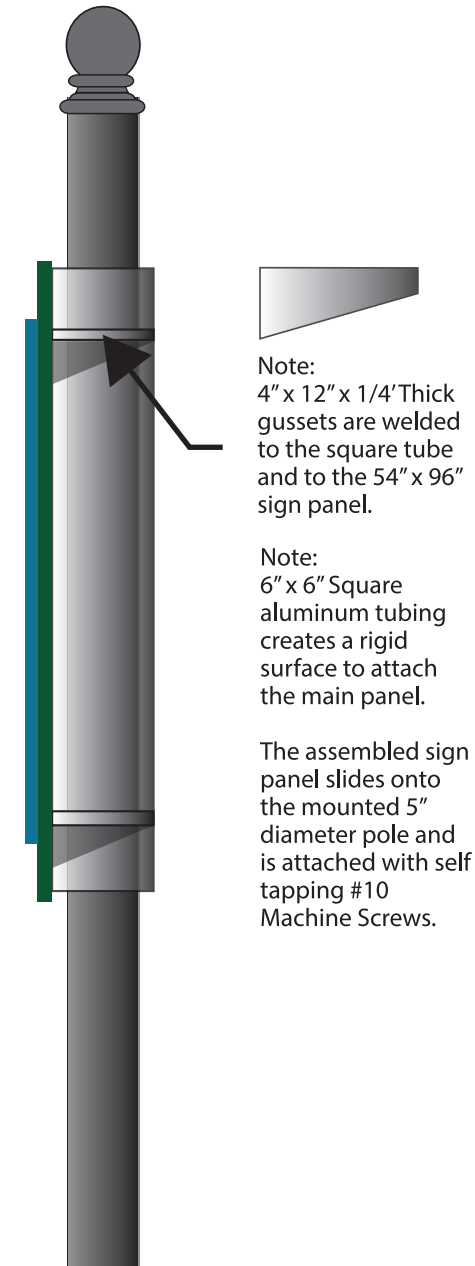

Note:  
4" x 12" x 1/4" Thick  
gussets are welded  
to the square tube  
and to the 54" x 96"  
sign panel.

Note:  
6" x 6" Square  
aluminum tubing  
creates a rigid  
surface to attach  
the main panel.

The assembled sign  
panel slides onto  
the mounted 5"  
diameter pole and  
is attached with self  
tapping #10  
Machine Screws.

**Note: Bizzell Design, Inc. will provide one full scale CNC cutting pattern and print file to be used by the sign company to set up each sign.**



Wayfinding / Messaging Details



Wayfinding / Messaging Details





Wayfinding / Messaging Details

**RO·WAN COUNTY**  
 NORTH CAROLINA  
*Be an original.*

Welcome to the Town of  
**CLEVELAND**  
 Connecting & Creating

**Town Hall**  
**Town Parks** ↑  
**Barn Quilt**  
**Mural & Trail**

CLD -5  
 Driving South at 625 Third Creek Church Road, sign is placed near Waste Water Treatment Plant.

**RO·WAN COUNTY**  
 NORTH CAROLINA  
*Be an original.*

Welcome to the Town of  
**CLEVELAND**  
 Connecting & Creating

**Town Hall** ←  
**Community Parks** ←  
**Barn Quilt** ↑  
**Mural & Trail** ↑

CLD -2  
 Driving East on Hwy 70  
 Sign positioned on West of S. Main St.

**RO·WAN COUNTY**  
 NORTH CAROLINA  
*Be an original.*

**Rowan County Attractions**  
 Zoo / Ranch ↑  
 Farm Tours ↑  
 Airport ↑  
 Downtown Salisbury ↑

1 - 150  
 Driving East positioned on Hwy 150 150 ft. East of London Rd.

**RO·WAN COUNTY**  
 NORTH CAROLINA  
*Be an original.*

**Rowan County Attractions**  
 Patterson Farms Tours & Farmers Market →  
 Sloan Park ↑  
 Airport ↑

2 - 150  
 Driving East positioned on Hwy 150 500 ft. West of Caldwell Rd.

**RO·WAN COUNTY**  
 NORTH CAROLINA  
*Be an original.*

**Rowan County Attractions**  
 Sloan Park  
 Historic Thyatira Presbyterian Church ←  
 West Rowan High  
 Public Golf →

3 - 150  
 Driving East positioned on Hwy 150 200 ft. West of Millbridge Rd.

**RO·WAN COUNTY**  
 NORTH CAROLINA  
*Be an original.*

**Rowan County Attractions**  
 Vineyard Tours ←  
 Mid- Carolina Airport →  
 Downtown Salisbury ↑

4 - 150  
 Driving East positioned on Hwy 150 300 ft. West of Airport Rd.

**RO·WAN COUNTY**  
 NORTH CAROLINA  
*Be an original.*

**Rowan County Attractions**  
 Vineyard Tours →  
 Mid- Carolina Airport ←  
 Ranch / Farm Tours ↑

5 - 150-W  
 Driving West positioned on Hwy 150 300 ft. East of Airport Rd.

**RO·WAN COUNTY**  
 NORTH CAROLINA  
*Be an original.*

**Rowan County Attractions**  
 Sloan Park  
 Historic Thyatira Presbyterian Church →  
 West Rowan High  
 Ranch / Farm Tours ↑

6 - 150 - W  
 Driving West positioned on Hwy 150 100 ft. East of Millbridge Rd.



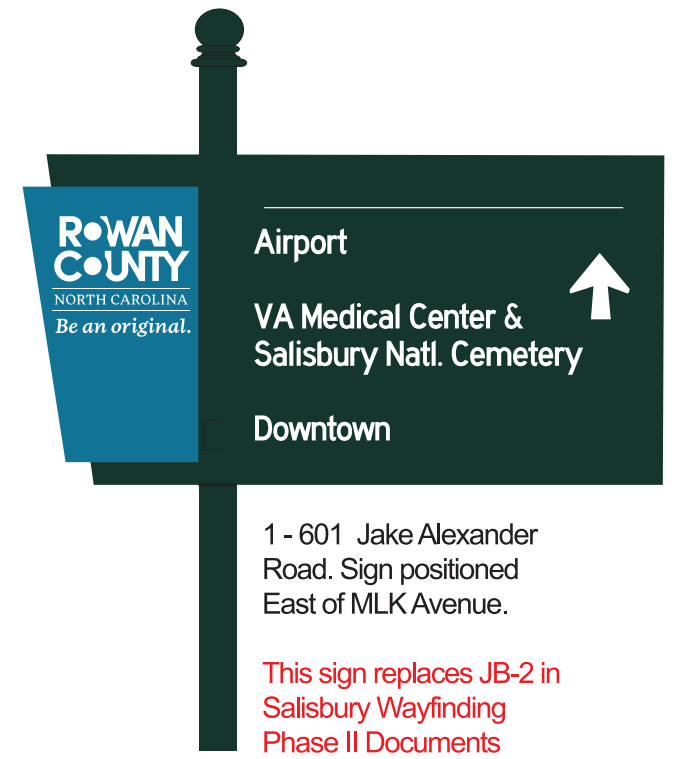
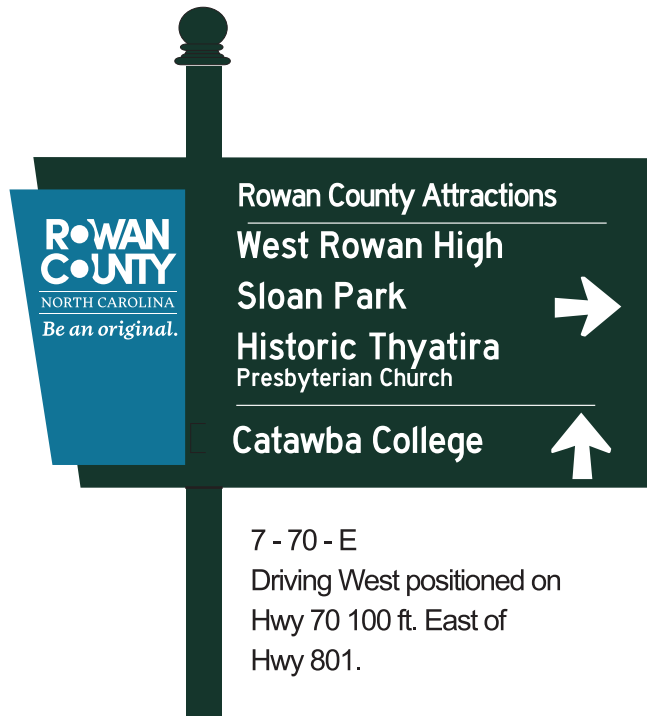

## Quality Standards

The materials, products, equipment and performance specifications described in this document, establish a standard of required function, dimension, appearance, performance and quality to be met by the Fabricator.

## Structural Design

Designs and details indicate the approach for sign structure but do not necessarily include all fabrication details required for the complete structural integrity of the signs, including consideration for static, dynamic and erection loads during handling, erecting, and service at the installed locations, nor do they consider the preferred shop practices of the individual Fabricator. Therefore, it shall be the responsibility of the Fabricator to perform the complete structural design and engineering of the signs and to incorporate all the safety features necessary to adequately support the sign for its intended use and purpose and to protect the Owner. Fabricator shall also be responsible for ensuring that all signs meet local, state and federal codes.

## Vandalism Design

Fabrication and installation design is to withstand severe abuse and souvenir theft vandalism, but not less than the equivalent of resisting simple hand implements and tools (screwdrivers, knives, coins, keys and similar items), and adult physical force. All hardware and fasteners within reach shall be vandal resistant.

## Substitution

No substitution will be considered unless the Owner has received written request for approval. Fabricator may recommend equal or better equipment or method, but will be required to provide full documentation establishing such a substitution's equality or superiority as measured in the following: The burden of proof of the merit of the proposed substitute is upon the Fabricator. The Owners decision of approval or disapproval of a proposed substitution shall be final.

## Material Handling

The Fabricator is to pack, wrap, crate, bundle, box, bag, or otherwise package handle, transport and store all fabricated work as necessary to provide protection from damage by every cause. Fabricator shall provide clear and legible identifying information on all product packaging to ensure proper on-site identification and installation.

## Sign Specifications

Construction Methodology. The drawings call for a variety of fabrication techniques. Fabricators are given leeway to construct the signs to meet the intent of the design depicted by the drawings. Because different systems of extrusions may result in slightly different dimensional requirements, the total height and width dimensions described in the sign construction on the drawings may be considered slightly variable for the purposes of cost quote. Sign faces are to be fabricated using aluminum plate of varying thicknesses, as specified with a minimum thickness of .125" inches unless otherwise noted. All finishes are to be free from fading, peeling or cracking. Paint and/or powder coat required preparation of all exterior metal surfaces of the sign to include removal of all scratches and imperfections, sanding and chemical etching. Substrate cleaning, preparation, paint and/or powder coat application and paint thickness to be in strict compliance with manufacturers published recommendations. Acceleration of the drying process is not allowed.

Any sign faces smaller than 5' by 9' are to be fabricated from 1 piece of seamless material.

Dimensional and structural welding defects will not be accepted, including but not limited to: Poor weld contours, including excessive bead convexity and reinforcement, and considerable concavity or under stainless steel as appropriate.

Non-welded joints between various portions of sign must have a tight, hairline-type appearance, without gaps. Provide sufficient fastenings to preclude looseness, racking, or similar movement.

Provide drain holes as needed to prevent accumulation of water within signs. Holes must be inconspicuous such that drainage does not occur onto signs, or other surfaces subject to staining. Provide internal system of baffles to prevent "light leaks" through drain holes illuminated signs. Provide color-coordinated insect screening over drain holes.

Non-illuminated sign faces are to have lettering and graphics created as surface-applied vinyl typography using Avery or 3M exterior grade, minimum 7-year warranty unless otherwise noted in the drawings.

## Font/Typefaces

The fonts used in these sign designs were selected specifically for this project by the Designer and Owner and are listed in the graphic standards. No substitutions are allowed. It is the Fabricators responsibility to acquire the required fonts and layout the specific sign panels as designed. Proofs should be submitted to the Owner/Designer for approval before final application of graphics.

Under no circumstances are typefaces to be electronically distorted ("squeezed" or "extended") for purposes of fitting to the specified sign or general alteration of the sign face composition unless noted in the drawings. This includes (but is not limited to) stretching, squeezing, tilting, outlining or shadowing.

All letterforms, symbols or graphics shall be reproduced either by photographic or computer-generated means. Hand-cut characters are not acceptable. Cutting shall be done in such manner that edges and corners of with nicked, cut, ragged, rounded corners, and similar disfigurements will not be acceptable.

All letterforms shall be made from material and gauge as indicated on the drawings. Typefaces shall be replicated as indicated on the drawing. Vinyl graphics and letterforms shall be computer-cut. Custom logos and symbols will be specified as vector art or digital art and supplied by the Owner or Designer. These symbols cannot be altered in any way.



## Permits and Variances

Fabricator shall be knowledgeable of relevant local code requirements and honor same in fabrication and installation. Fabricator is responsible for securing any and all necessary permits for signage installation. It is the responsibility of the Owner to secure encroachment permissions from property Owners including Department of Transportation. It is the responsibility of the Owner to secure variances, should any be required. It is the Owner's responsibility to call the appropriate agency to have all underground utilities properly located and marked. Any damage to below-grade utilities or structures for which the Owner has provided adequate location information is the responsibility of the Fabricator.

## Site Visit

Prior to installation of the signs, the Fabricator is to visit the proposed site to observe existing conditions and verify all signage required and its location with Owner. At this time the locations shall be staked using a non-permanent visible device such as a spray chalk or non-permanent paint. Certain signs may be located on sloped grades and may require uneven footings for each post. Site-verify all locations to determine special requirements for footing templates, if required. Shall be consulted together and shall be approved by the Owner to determine the precise location for each sign. Any necessary adjustments will be marked with the approval of the Owner. Site conditions unacceptable for installation will require improvement by the Owner, or alternate location if possible.

## Masonry/Footings

Any concrete bases for signage are to be poured in place and footings are to extend beneath the frost line, or deeper to meet local code. All footings or bases should be poured within a form and level with grade unless otherwise specified in the design intent drawings. Foundation/footings should be level with grade unless otherwise noted or as specified by state or local code. Foundation/footings should not extend above grade more than 2" and exposed edges should be finished with a bevel to prevent chipping. It is recommended that the concrete be floated by machine or hand before finishing in order to embed larger aggregates especially when part of the footing or base extends above ground. Concrete surface should have a smooth or brushed finish grade appearance. All concrete bases and footings should be edged to break any bond with the form and create a neat appearance. All forms should be removed once the concrete has properly cured. Concrete and reinforcement specifications shall be shown on shop drawing submittals. The Fabricator is responsible for the necessary templates, mounting plates and hardware for concrete and masonry bases. A minimum 1' rock bed with landscape edging or concrete pad must be added around each concrete base as protection from landscaping maintenance. All masonry (concrete block, poured concrete, brick, slab, veneer, mortar, etc.) is to be properly treated and protected to maintain the structural integrity of the masonry work with exposure to all environmental conditions found at the site. For exposed or visible masonry, this shall include the application of protective sealers or similar finishes to diminish the effects of close-proximity sprinkling or irrigation systems. Signs are to be mounted on J-bolt footings, centered on the concrete base or footing, and engineered per code, breakaway if required unless otherwise specified in the design intent drawings.

## Wind Load

Signs, banners and mounting devices shall be engineered to withstand a minimum 30-psf wind load normal to the sign, or greater as per local code, in addition to the weight of the sign. The Fabricator shall determine appropriate method of anchoring signs to the locations specified to meet these requirements as well as all local code requirements.

## Mounting

All signs to be mounted level and true. All exposed hardware is to be touch-up painted on site as required. It is preferred that all bolts, nuts, washers or other fasteners shall be stainless steel. However, galvanized steel is acceptable, so long as all exposed surfaces are sealed. Mounting and/or mounting hardware details, the Fabricator will be able to substitute equal or better hardware and techniques, based upon their experience with similar mounting situations and as long as the visual appearance of the sign is not compromised from that shown in the drawings.

All signage products must be installed such that there are no misalignments between visible components. Sign elements intended to be removable or changeable after installation must function as intended without binding, sticking or blocking. It will be the responsibility of the Fabricator to correct any installation misalignments at no charge. Fabricator and their Installers are expected to have knowledge of ADA mounting guidelines and city zoning codes, general sign location practices, and any particular unique installations defined by Designer. It is the desire of the Owner that the Fabricator follow these guidelines as well as architectural cues in installing for the best visual placement, keeping a reasonable distance from protruding objects. Any signage that is improperly located is to be moved to the proper location by the Fabricator/Installer, and repairs to wall surfaces and signage are to be at the Fabricator/Installer, and repairs to wall surfaces and signage are to be at the Fabricator/Installer, expense. If the Installer are unable to make decision about any sign locations, they can contact the Designer, providing a graphic representation of the questionable area or contact the Owner for on-site options.

## Electrical

The Owner will be responsible for providing a power source to within 10 feet of the base of each sign requiring power (either at grade or below grade). Power is to be 120 or 277 . It is the responsibility of the Fabricator to manipulate the existing conduit to its proper location, install an external disconnect, extend conduit through the concrete base (or posts) to align with the point of hookup, and run the power supply through it. Conduit running from the disconnect to the sign shall travel within the concrete base, not on its surface. The Owner will be responsible for the final electrical connection.

## Punchlist

It is required that the Fabricator complete a walk through with the Owner immediately following installation to identify any errors, such as construction or installation issues. Such errors are to be corrected in a timely manner, and to be satisfaction of the Owner.

## Signage Warranty

Fabricator is solely responsible for applying products (paints, finishes, components, etc.) according to manufacturers' specifications and validating the warranty. The Fabricator is to provide a written five (5) year full replacement warranty to the Owner that all signs will be free of defects due to workmanship and materials including, but not limited to: sign faces, brackets, posts or other support assemblies. Vinyl sheeting, lettering, paint and or powder coat finishes will be warranted to manufacturer's stated guarantees. All selected materials will require a minimum of seven year performance. Fabricator shall also extend in writing to the Owner all manufacturers' warranties.

## Repair and Replacement

The Fabricator will be required to repair or replace, including installation, any defective signs or hardware that develop during the warranty period and repair any damage to other work due to such imperfections. The Fabricator will be required to fully replace all signs that are in error relative to the working documents (sign message schedule and sign type drawings) that were submitted to the Fabricator as final version after awarded contract.



## Rowan County NC Wayfinding . Pedestrian Scale Signage

China Grove • Rockwell • Cleveland  
Landis • Spencer • East Spencer • Granite Quarry • Faith

Final Revision / March 12, 2024



# Wayfinding /

## Typical Wayfinding Fabrication Details

**NOTE: ALL DESTINATIONS LISTED ARE CITY OWNED PUBLIC ART, EDUCATIONAL AND CULTURAL FACILITIES.**  
**All destination lettering is 4-Inch in height per MUTCD standards**

General Comments:

Standard MUTCD Approved font is "Highway Gothic"

All materials and workmanship should be warranted for 10 years.

Selected fabrication firm will receive vector patterns for messaging and graphics and actual color samples for powder coated finishes from Bizzell Design, Inc.

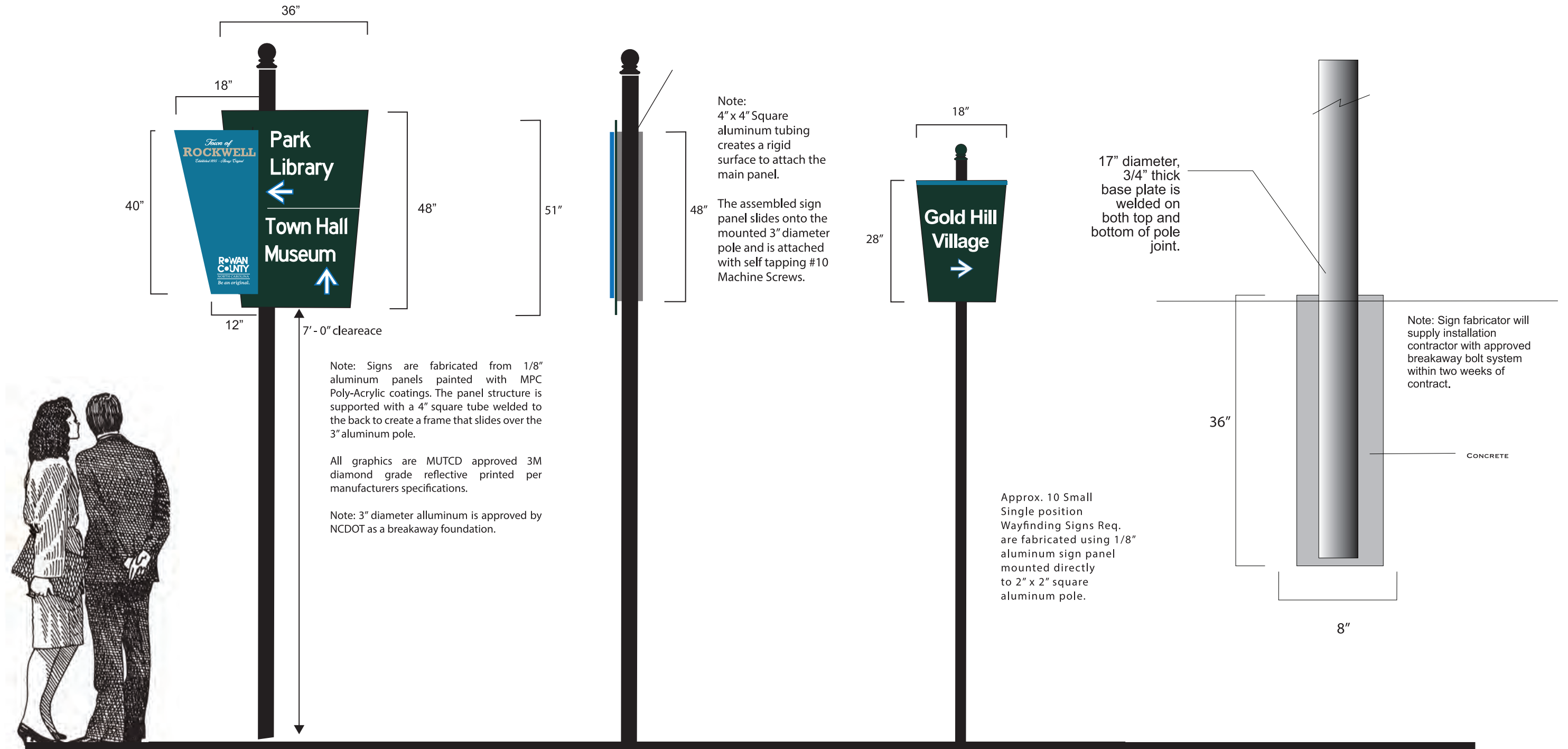

**46 Small Wayfinding Signs Req.**





**Wayfinding / Fabrication / Messaging Details**

MUTCD Guidelines : The principal legend for signs placed on streets 25mph or below should be 4" in height.

MUTCD Lettering is Highway Gothic  
**ABCDEFGHIJKLMNOPQRSTUVWXYZ**  
**abcdefghijklmnopqrstuvwxyz 1234567890**



Pantone 3308



MPC - 33764



Note: Signs are fabricated from 1/8" aluminum panels painted with MPC Poly-Acrylic coatings. The panel structure is supported with a 4" square tube welded to the back to create a frame that slides over the 3" aluminum pole.

All graphics are MUTCD approved 3M diamond grade reflective printed per manufacturers specifications.

Note: 3" diameter aluminum is approved by NCDOT as a breakaway foundation.

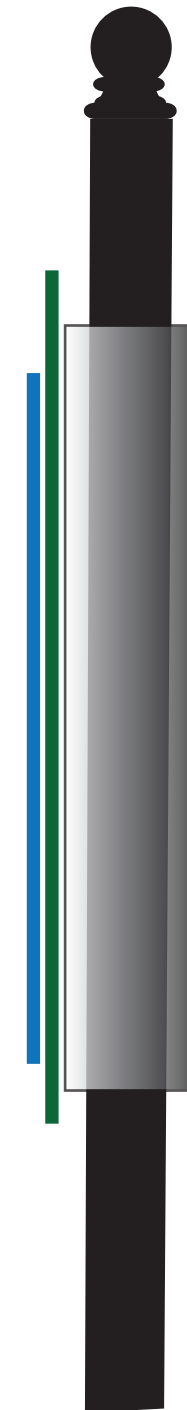

Note:  
 4" x 4" Square aluminum tubing creates a rigid surface to weld the main panel.

The assembled sign panel slides onto the mounted 3" diameter pole and is attached with self tapping #10 Machine Screws.

**Note: Bizzell Design, Inc. will provide one full scale CNC cutting pattern and print file to be used by the sign company to set up each sign.**



Wayfinding / Messaging Details



Faith Location 0-1  
Driving South Sign  
positioned on Faith  
Road at Gardner St.



Faith Location 2  
Driving South  
Sign positioned  
on Faith Road at  
Byrd Rd



Faith Location 4  
Driving South  
Sign positioned  
on Faith Road  
at Gantt St.



Faith Location 5  
Driving South  
Sign positioned  
on Faith Road  
at Quarry St.



Faith Location 8  
Driving North-  
Sign positioned  
on Faith Rd.  
Near Blue  
Waters Dr.



Faith Location 10  
Driving North Sign  
positioned on  
Faith Road  
at Gantt St.



Granite Quarry  
Location 4  
Driving South, Sign  
positioned on Hwy 52  
north of E. Lyerly  
Street which turns into  
Old Stone House Rd.



Granite Quarry Location 4-B  
Driving North, Sign positioned  
on Hwy 52 south of E. Lyerly  
Street which turns into Old  
Stone House Rd.



Rockwell Location 1-B  
Driving south sign positioned  
on Hwy 52  
at Parking Lot

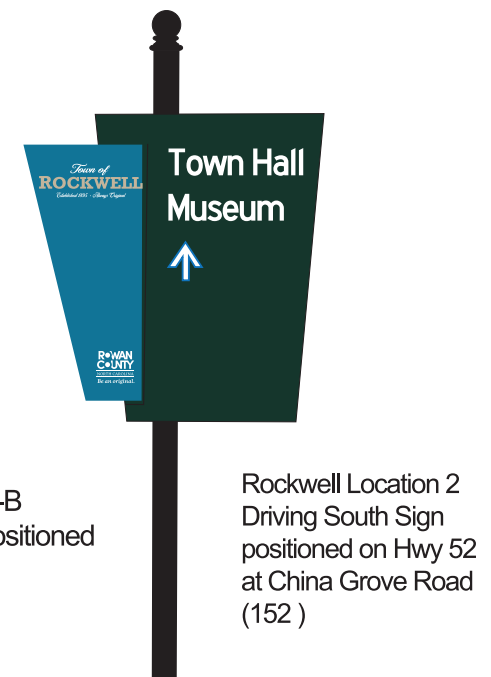

Rockwell Location 2  
Driving South Sign  
positioned on Hwy 52  
at China Grove Road  
(152)



Wayfinding / Messaging Details



Rockwell Location 3  
Driving south sign positioned  
on Hwy 52  
north of Depot St



Rockwell Location 3-B  
Driving north sign positioned  
on Hwy 52  
south of Depot St



**CG-3**  
China Grove Location 3  
Driving West  
Sign positioned on Church  
St. at N. Bostian Ave.



**CG-4**  
China Grove Location 4  
Driving West  
Sign positioned on Church St.  
at Main Street /29



**CG-N-3A**  
China Grove Location N-3  
Driving North  
Sign positioned on Center-  
view Street & Bostian



**CG-N-4 SP**  
China Grove Location N- 4  
Driving North  
Sign positioned N Main Street-  
Street at Church Street



**CG-N-5**  
China Grove Location N- 5  
Driving East  
Sign positioned Church Street  
at Bostian Ave.



Landis Location LND-N-2  
Driving North Sign positioned  
on S. Main  
South of Rice Road



Landis Location LND-N -3  
Driving North Sign  
positioned on S. Main  
South of Ryder Road



Landis Location LND-N -5  
Driving West on Moriah  
Church Rd. Sign is  
Positioned on Private Road  
East Entrance

Wayfinding / Messaging Details

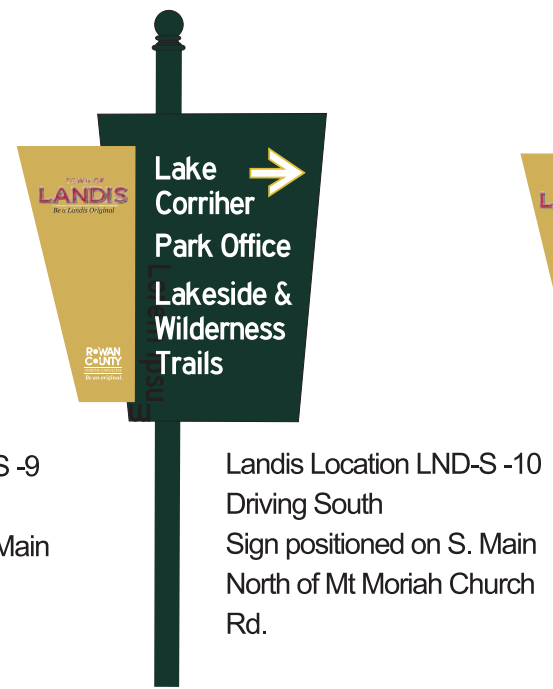
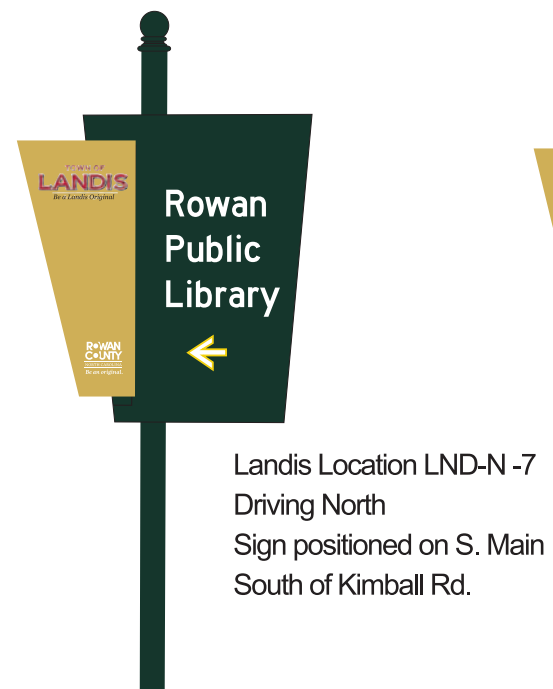

# Wayfinding / Messaging Details



W-CLD -2  
Driving North on School Road Sign positioned on South of W. Main Street



CLD -4  
Driving West on Old US 70 Sign is placed near Christ Episcopal Church



SP- N- 3  
Driving North Sign positioned on Salisbury Ave. @8th St.



SP- N -4  
Driving North Sign positioned on Salisbury Ave. @5th St.



SP- N -5  
Driving North Sign positioned on Salisbury Ave. @4th St.



SP- N - 6  
Driving North Sign positioned on Salisbury Ave. @Harrison St.



SP-S-3B  
Driving South on Salisbury Ave @ Jefferson St



SP-S- 3  
Driving South on Salisbury Ave. @ Sammuel E Spencer Blvd



SP-S- 4  
Driving South on Salisbury Street @ 4th Ave.



SP-S- 5  
Driving South on Salisbury Street @ 5th Ave.

Wayfinding / Messaging Details



### **Quality Standards**

The materials, products, equipment and performance specifications described in this document, establish a standard of required function, dimension, appearance, performance and quality to be met by the Fabricator.

### **Structural Design**

Designs and details indicate the approach for sign structure but do not necessarily include all fabrication details required for the complete structural integrity of the signs, including consideration for static, dynamic and erection loads during handling, erecting, and service at the installed locations, nor do they consider the preferred shop practices of the individual Fabricator. Therefore, it shall be the responsibility of the Fabricator to perform the complete structural design and engineering of the signs and to incorporate all the safety features necessary to adequately support the sign for its intended use and purpose and to protect the Owner. Fabricator shall also be responsible for ensuring that all signs meet local, state and federal codes.

### **Vandalism Design**

Fabrication and installation design is to withstand severe abuse and souvenir theft vandalism, but not less than the equivalent of resisting simple hand implements and tools (screwdrivers, knives, coins, keys and similar items), and adult physical force. All hardware and fasteners within reach shall be vandal resistant.

### **Substitution**

No substitution will be considered unless the Owner has received written request for approval. Fabricator may recommend equal or better equipment or method, but will be required to provide full documentation establishing such a substitution's equality or superiority as measured in the following: The burden of proof of the merit of the proposed substitute is upon the Fabricator. The Owners decision of approval or disapproval of a proposed substitution shall be final.

### **Material Handling**

The Fabricator is to pack, wrap, crate, bundle, box, bag, or otherwise package handle, transport and store all fabricated work as necessary to provide protection from damage by every cause. Fabricator shall provide clear and legible identifying information on all product packaging to ensure proper on-site identification and installation.

### **Sign Specifications**

Construction Methodology. The drawings call for a variety of fabrication techniques. Fabricators are given leeway to construct the signs to meet the intent of the design depicted by the drawings. Because different systems of extrusions may result in slightly different dimensional requirements, the total height and width dimensions described in the sign construction on the drawings may be considered slightly variable for the purposes of cost quote. Sign faces are to be fabricated using aluminum plate of varying thicknesses, as specified with a minimum thickness of .125" inches unless otherwise noted. All finishes are to be free from fading, peeling or cracking. Paint and/or powder coat required preparation of all exterior metal surfaces of the sign to include removal of all scratches and imperfections, sanding and chemical etching. Substrate cleaning, preparation, paint and/or powder coat application and paint thickness to be in strict compliance with manufacturers published recommendations. Acceleration of the drying process is not allowed.

Any sign faces smaller than 5' by 9' are to be fabricated from 1 piece of seamless material.

Dimensional and structural welding defects will not be accepted, including but not limited to: Poor weld contours, including excessive bead convexity and reinforcement, and considerable concavity or under stainless steel as appropriate.

Non-welded joints between various portions of sign must have a tight, hairline-type appearance, without gaps. Provide sufficient fastenings to preclude looseness, racking, or similar movement.

Provide drain holes as needed to prevent accumulation of water within signs. Holes must be inconspicuous such that drainage does not occur onto signs, or other surfaces subject to staining. Provide internal system of baffles to prevent "light leaks" through drain holes illuminated signs. Provide color-coordinated insect screening over drain holes.

Non-illuminated sign faces are to have lettering and graphics created as surface-applied vinyl typography using Avery or 3M exterior grade, minimum 7-year warranty unless otherwise noted in the drawings.

### **Font/Typefaces**

The fonts used in these sign designs were selected specifically for this project by the Designer and Owner and are listed in the graphic standards. No substitutions are allowed. It is the Fabricators responsibility to acquire the required fonts and layout the specific sign panels as designed. Proofs should be submitted to the Owner/Designer for approval before final application of graphics.

Under no circumstances are typefaces to be electronically distorted ("squeezed" or "extended") for purposes of fitting to the specified sign or general alteration of the sign face composition unless noted in the drawings. This includes (but is not limited to) stretching, squeezing, tilting, outlining or shadowing.

All letterforms, symbols or graphics shall be reproduced either by photographic or computer-generated means. Hand-cut characters are not acceptable. Cutting shall be done in such manner that edges and corners of with nicked, cut, ragged, rounded corners, and similar disfigurements will not be acceptable.

All letterforms shall be made from material and gauge as indicated on the drawings. Typefaces shall be replicated as indicated on the drawing.

Vinyl graphics and letterforms shall be computer-cut. Custom logos and symbols will be specified as vector art or digital art and supplied by the Owner or Designer. These symbols cannot be altered in any way.



## Permits and Variances

Fabricator shall be knowledgeable of relevant local code requirements and honor same in fabrication and installation. Fabricator is responsible for securing any and all necessary permits for signage installation. It is the responsibility of the Owner to secure encroachment permissions from property Owners including Department of Transportation. It is the responsibility of the Owner to secure variances, should any be required. It is the Owner's responsibility to call the appropriate agency to have all underground utilities properly located and marked. Any damage to below-grade utilities or structures for which the Owner has provided adequate location information is the responsibility of the Fabricator.

## Site Visit

Prior to installation of the signs, the Fabricator is to visit the proposed site to observe existing conditions and verify all signage required and its location with Owner. At this time the locations shall be staked using a non-permanent visible device such as a spray chalk or non-permanent paint. Certain signs may be located on sloped grades and may require uneven footings for each post. Site-verify all locations to determine special requirements for footing templates, if required. Shall be consulted together and shall be approved by the Owner to determine the precise location for each sign. Any necessary adjustments will be marked with the approval of the Owner. Site conditions unacceptable for installation will require improvement by the Owner, or alternate location if possible.

## Masonry/Footings

Any concrete bases for signage are to be poured in place and footings are to extend beneath the frost line, or deeper to meet local code. All footings or bases should be poured within a form and level with grade unless otherwise specified in the design intent drawings. Foundation/footings should be level with grade unless otherwise noted or as specified by state or local code. Foundation/footings should not extend above grade more than 2" and exposed edges should be finished with a bevel to prevent chipping. It is recommended that the concrete be floated by machine or hand before finishing in order to embed larger aggregates especially when part of the footing or base extends above ground. Concrete surface should have a smooth or brushed finish grade appearance. All concrete bases and footings should be edged to break any bond with the form and create a neat appearance. All forms should be removed once the concrete has properly cured. Concrete and reinforcement specifications shall be shown on shop drawing submittals. The Fabricator is responsible for the necessary templates, mounting plates and hardware for concrete and masonry bases. A minimum 1' rock bed with landscape edging or concrete pad must be added around each concrete base as protection from landscaping maintenance. All masonry (concrete block, poured concrete, brick, slab, veneer, mortar, etc.) is to be properly treated and protected to maintain the structural integrity of the masonry work with exposure to all environmental conditions found at the site. For exposed or visible masonry, this shall include the application of protective sealers or similar finishes to diminish the effects of close-proximity sprinkling or irrigation systems. Signs are to be mounted on J-bolt footings, centered on the concrete base or footing, and engineered per code, breakaway if required unless otherwise specified in the design intent drawings.

## Wind Load

Signs, banners and mounting devices shall be engineered to withstand a minimum 30-psf wind load normal to the sign, or greater as per local code, in addition to the weight of the sign. The Fabricator shall determine appropriate method of anchoring signs to the locations specified to meet these requirements as well as all local code requirements.

## Mounting

All signs to be mounted level and true. All exposed hardware is to be touch-up painted on site as required. It is preferred that all bolts, nuts, washers or other fasteners shall be stainless steel. However, galvanized steel is acceptable, so long as all exposed surfaces are sealed. Mounting and/or mounting hardware details, the Fabricator will be able to substitute equal or better hardware and techniques, based upon their experience with similar mounting situations and as long as the visual appearance of the sign is not compromised from that shown in the drawings.

All signage products must be installed such that there are no misalignments between visible components. Sign elements intended to be removable or changeable after installation must function as intended without binding, sticking or blocking. It will be the responsibility of the Fabricator to correct any installation misalignments at no charge. Fabricator and their Installers are expected to have knowledge of ADA mounting guidelines and city zoning codes, general sign location practices, and any particular unique installations defined by Designer. It is the desire of the Owner that the Fabricator follow these guidelines as well as architectural cues in installing for the best visual placement, keeping a reasonable distance from protruding objects. Any signage that is improperly located is to be moved to the proper location by the Fabricator/Installer, and repairs to wall surfaces and signage are to be at the Fabricator/Installer, and repairs to wall surfaces and signage are to be at the Fabricator/Installer, expense. If the Installer are unable to make decision about any sign locations, they can contact the Designer, providing a graphic representation of the questionable area or contact the Owner for on-site options.

## Electrical

The Owner will be responsible for providing a power source to within 10 feet of the base of each sign requiring power (either at grade or below grade). Power is to be 120 or 277 . It is the responsibility of the Fabricator to manipulate the existing conduit to its proper location, install an external disconnect, extend conduit through the concrete base (or posts) to align with the point of hookup, and run the power supply through it. Conduit running from the disconnect to the sign shall travel within the concrete base, not on its surface. The Owner will be responsible for the final electrical connection.

## Punchlist

It is required that the Fabricator complete a walk through with the Owner immediately following installation to identify any errors, such as construction or installation issues. Such errors are to be corrected in a timely manner, and to be satisfaction of the Owner.

## Signage Warranty

Fabricator is solely responsible for applying products (paints, finishes, components, etc.) according to manufacturers' specifications and validating the warranty. The Fabricator is to provide a written five (5) year full replacement warranty to the Owner that all signs will be free of defects due to workmanship and materials including, but not limited to: sign faces, brackets, posts or other support assemblies. Vinyl sheeting, lettering, paint and or powder coat finishes will be warranted to manufacturer's stated guarantees. All selected materials will require a minimum of seven year performance. Fabricator shall also extend in writing to the Owner all manufacturers' warranties.

## Repair and Replacement

The Fabricator will be required to repair or replace, including installation, any defective signs or hardware that develop during the warranty period and repair any damage to other work due to such imperfections. The Fabricator will be required to fully replace all signs that are in error relative to the working documents (sign message schedule and sign type drawings) that were submitted to the Fabricator as final version after awarded contract.